

**DURAGRIP AUTO-VOLTAGE
SPOOL-ON
MIG/MAG SERIES**

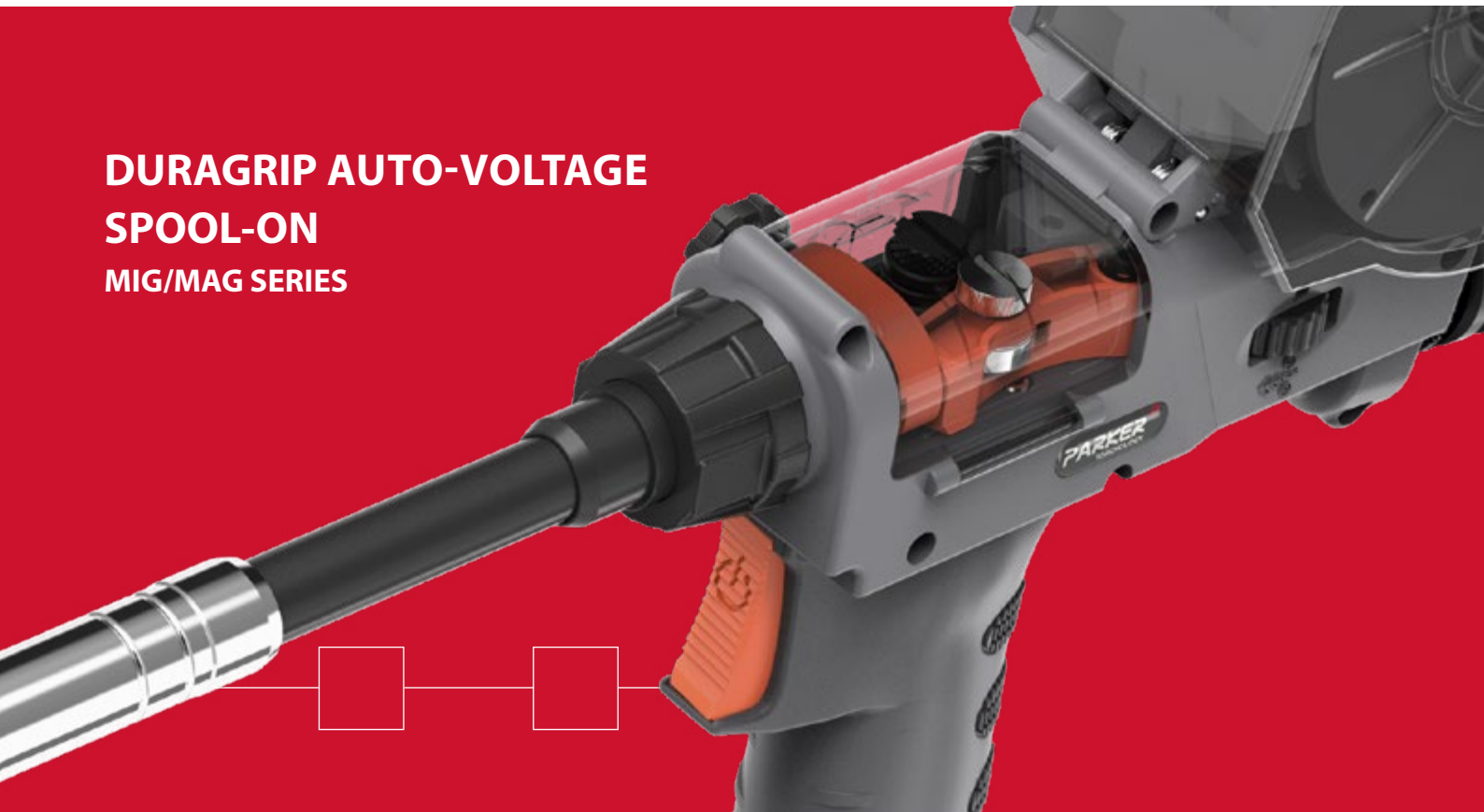

Welding Tools for the Professional

A Smart Approach

Parker Torchology is shaped by people with vision, a passion for improvement and a belief in delivering the very best Welding and Cutting Torch Range in the World.

We expect a great deal from our products, so we ask a lot of ourselves and our engineers.

Our mantra: **Innovation, Technology, Performance.**



DNA

Design and Engineering excellence are at the core of everything we do.

Every torch we build is driven by our relentless pursuit of perfection.

Premium Features

At Parker Torchology we do things differently, we strive to solve your problems with the perfect product to suit your needs. We create smart product features encased in cutting-edge design to ensure you always have the best tools to hand.





Production

A fusion of precision production engineering, our bespoke processing techniques and a fanatical attention to detail ensures every welding torch we produce is worthy of the Parker Torchology name.

Testing, Testing, Testing

It takes patience to develop a new product, it's a lot more than a great idea.

Product development is an iterative process, trying something over and over, changing one small variable at a time.

We build endless prototypes and test pieces that undergo months of rigorous testing. Only once a product has passed up to 88 different test procedures, with every single part tested separately do we consider our latest designs ready for market.

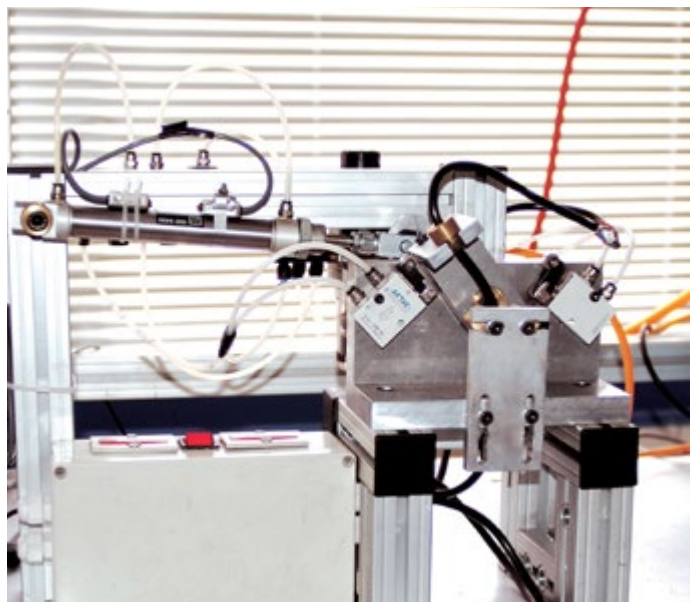

Partners

Our customers and business partners play a vital role in our development. With the core aim to strive together, we work with end-users, distributors and academic institutions alike.

As a result we share fundamental values in order to succeed in our respective market places, supporting economic growth and collaborative opportunities with others.



A Bright Future

Technology doesn't stand still, which is why we are constantly innovating to bring you the best products on the market.

Our strong vision and focused innovation strategy, not to mention our passion to revolutionize the industry, ensure that Parker Torchology is a byword for excellence.

We Talk Torches

Contents

Duragrip Auto-Voltage Spool-On Mig/Mag Torch Range Features Focus	6
Duragrip Auto-Voltage Spool-On Mig/Mag Torch Range Overview and Ratings	8

Torch Range

Duragrip Auto-Voltage Spool-On Mig/Mag DSPAV 150A	10
Duragrip Auto-Voltage Spool-On Mig/Mag DSPAV 240A	12
Duragrip Auto-Voltage Spool-On Mig/Mag DSPAV 250A	14
Duragrip Auto-Voltage Spool-On Mig/Mag DSPAV 360A	16

Wear Parts

Nozzles	18
Contact Tips	19
Tip Adaptors	20
Diffusers	20

Rear-End Spare Parts	21
----------------------	----

Auto-Voltage Air-Cooled

Duragrip Auto-Voltage Spool-On Mig/Mag Gun Range

Air-Cooled Features Focus

Air-Cooled

Automatic Voltage Adjustment Guns can be mounted directly to the power source without the need to identify motor input voltage or the re-configuration of power source wiring systems.

The on-torch mounted control unit automatically configures the required motor voltage and integrates with the power source.

A Cost Effective Solution for Long Distance and Low Deposition Welding



100% Binzel® Wear Parts Compatibility Guaranteed

Quality Wear Parts

All wear parts are manufactured to exacting specifications ensuring reliability, longevity and superior performance

- The same wear parts are utilized as standard BZL ranges minimizing stock handling

Ergonomics – For Comfort and Handleability

Every detail has been considered to ensure the welder has the very best handling

- New lightweight single piece coax system
- A knuckle joint enables small movements of the handle independently of the cable assembly
- Improved balance and positionability resulting in reduced welder fatigue



Infinately Adjustable Wire Tension

- A unique lever action wire retainer and brake system holds all soft wire spools in place at the correct brake tension
- A further secondary brake system is integrated into the spool holder for independent adjustment of larger steel wires on all torches over 200 Amp

Features Focus

Welding Tools for the Professional



Precision and Visibility

- Precise and constant wire feed
- Contact pressure of the feed rollers regulated directly on the handle
- Transparent window for quick and easy reference to all moving parts
- Rapid access for wire changes

Torch mounted control system

No machine wiring required

- Single voltage motor suits all power source types
- On-torch speed adjustability
- Faster wire speeds than conventional PCB system



Terminations

- Terminations available in Euro and direct plug options
- The Euro body has been redesigned to improve gas seal integrity in Argon applications
- Our spring pins – often copied,, can't be beaten

The Smart Way To Buy Welding and Cutting Tools





Model	DSPAV 150A	DSPAV 240A
Technical Data		
Cooling Method	Air-Cooled	Air-Cooled
Rating: CO ₂	180A	250A
Rating: Mixed Gas	150A	220A
Duty Cycle	35%	35%
Wire Size: AL	0.8-1.0	0.8-1.2
Wire Size: Steel	0.8-1.0	0.8-1.0
Motor Voltage	24V	24V
Motor Life	1000 Hours	1000 Hours

Order Codes	6mt	DSPAV150A-A180-P10-60ER	DSPAV240A-A180-P10-60ER
	8mt	DSPAV150A-A180-P10-80ER	DSPAV240A-A180-P10-80ER

Duragrip Auto-Voltage Spool-On Mig/Mag Torch Range

Ratings: 150 Amp to 270 Amp, Mixed Gas



Model	DSPAV 250A	DSPAV 360A	
-------	------------	------------	--

Technical Data

Cooling Method	Air-Cooled	Air-Cooled	
Rating: CO ₂	230A	300A	270A
Rating: Mixed Gas	200A	270A	250A
Duty Cycle	35%	35%	
Wire Size: AL	0.8-1.2	0.8-1.2	
Wire Size: Steel	0.8-1.0	0.8-1.0	
Motor Voltage	24V	24V	
Motor Life	1000 Hours	1000 Hours	

Order Codes	6mt	8mt
	DSPAV250A-A180-P10-60ER	DSPAV250A-A180-P10-80ER
	DSPAV360A-A45-P10-60ER	DSPAV360A-A45-P10-80ER
	DSPAV360A-A180-P10-60ER	DSPAV360A-A180-P10-80ER

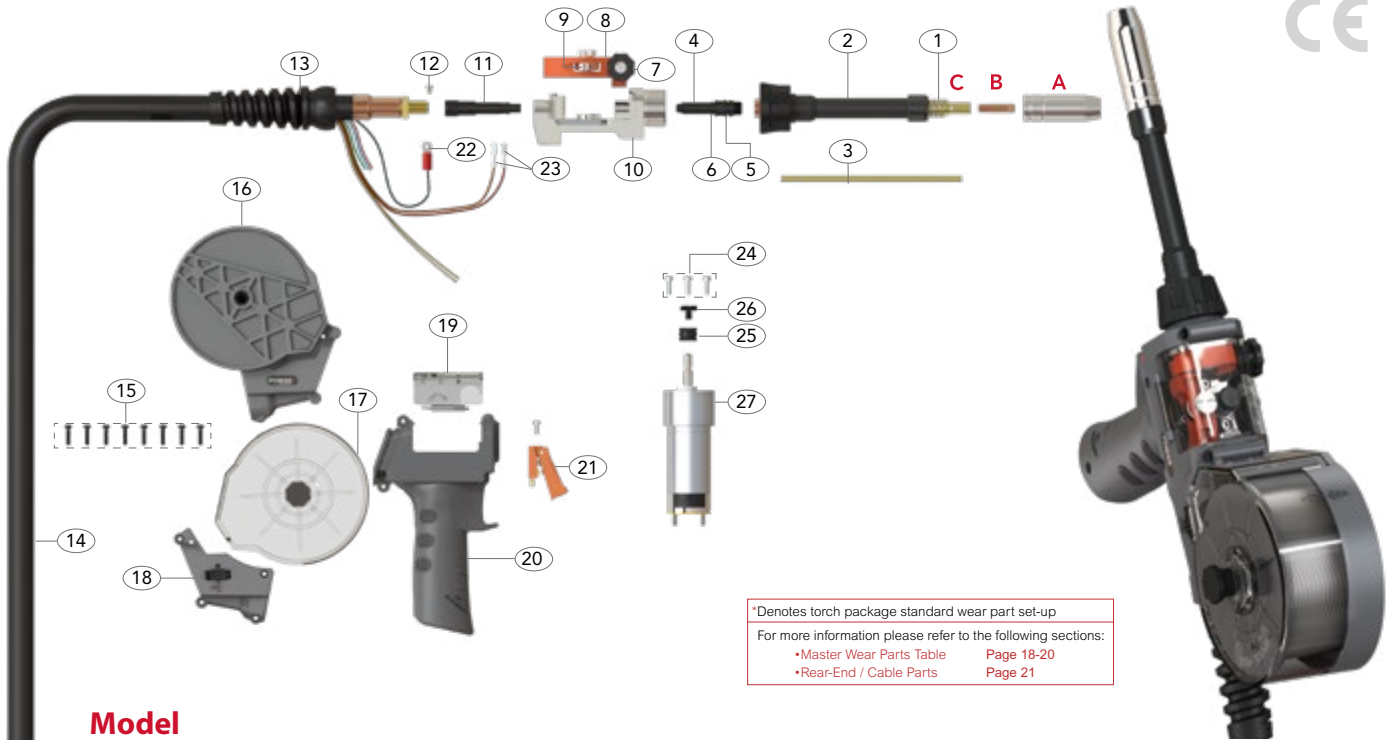

*Denotes torch package standard wear part set-up
For more information please refer to the following sections:
•Master Wear Parts Table Page 18-20
•Rear-End / Cable Parts Page 21

Model

Description	Part No.	
Duragrip AV Spool-On Mig Torch Package Straight Neck, Euro End	6mt	8mt
	DSPAV150A-A180-P10-60ER	DSPAV150A-A180-P10-80ER

Wear Parts

A Nozzles

Part No.	Description	Wall	Material	Bore
PB1529	Cylindrical Nozzle	0.9mm	Cu	16.0
*PB1530	Conical Nozzle	0.9mm	Cu	12.0
PB1531	Tapered Nozzle	0.9mm	Cu	10.5
PB1532	Bottle Nozzle	0.9mm	Cu	12.8
PB1533	Spot Welding Nozzle	0.9mm	Cu	16.0

C Tip Adaptors

Part No.	Description	Material
*PB1507L/H	Tip Adaptor Left Hand	Brass

B Contact Tips

Part No.	Description	Material	Wire Size	
			mm	Inch
*PB1527-08	Contact Tip	Cu	0.8	0.030
PB1527-09	Contact Tip	Cu	0.9	0.035
PB1527-10	Contact Tip	Cu	1.0	0.040

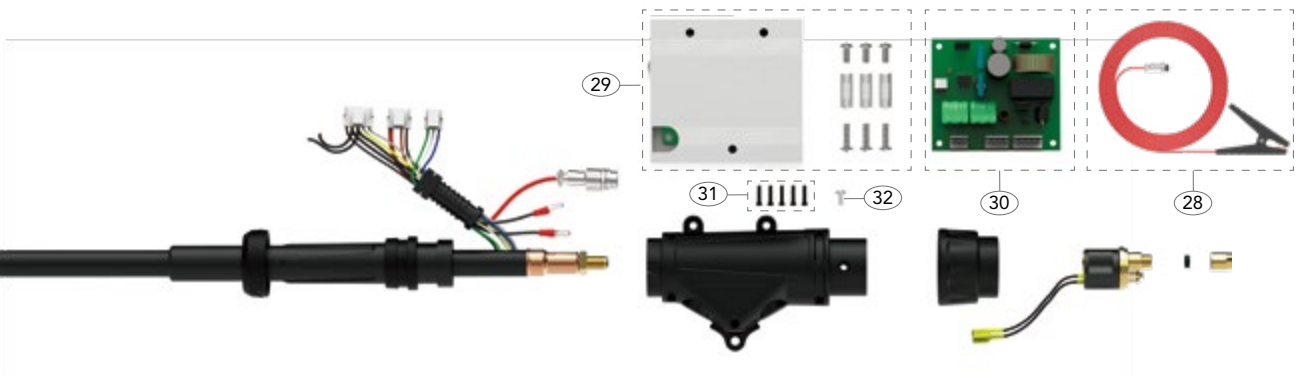

DSPAV 150A Duragrip Spool-On Mig/Mag Torch Range

Rating: 180A CO₂, 150A mixed gas, EN60974-7 @ 35% duty cycle. 0.8 to 1.0mm wires

Air-Cooled Mig Welding Torch



Spare Parts

Part No.	Description
1	PB1504 Shroud Spring
2	PSP1501 Straight Neck Assembly
3	PSP1502 Jump Liner
4	PGP36006 Jump Liner Nipple
5	P9X1.5 'O' Ring
6	P7X1.5 'O' Ring
7	PGP36402B Tension Knob
8	PGP36402 Pressure Arm Assembly
9	PGP36402R Pressure Roll
10	PSP36001 Motor Body
11	PSP36006 Wire Guide Tube
12	SCP2563 Screw
13	PMIG8015 Cable Support
14	DSPCB1517-60ER Coax Cable Assemblby Euro Type x 6mt
	DSPCB1517-80ER Coax Cable Assemblby Euro Type x 8mt
15	PKA3X20 Handle Screw
16	PCSP2515SP-B Wire Spool Holder
17	PSP2515SP-C Wire Spool Cover
18	PSP2515SP-PT-10K Wire Speed Control 10K Ω
19	PGP2514-C Push-Pull Handle Cover
20	PCSP2515-KJ Spool-On Handle

Part No.	Description
21	PGP2516 Standard Trigger Assembly
22	SCP2597 Circular Cable Terminal
23	PB1521 Cable Terminal
24	PGPMS1 Motor Screw
25*	SGP7020W-08 Drive Roll For Hard Wire φ 0.8
	SGP7020W-09 Drive Roll For Hard Wire φ 0.9
	SGP7020W-10 Drive Roll For Hard Wire φ 1.0
	SGP7020W-08U Drive Roll For Aluminium Wire φ 0.8
	SGP7020W-09U Drive Roll For Aluminium Wire φ 0.9
	SGP7020W-10U Drive Roll For Aluminium Wire φ 1.0
26	PGP7020-24-4 Drive Roller Retaining Screw
27	SGP7020-24 Motor 24V DC
28	PSP-EL Earth Lead Wire c/w Clamp x 4mt
29	PSPCB-BOX Control Box And Mounting Kit
30	PSPCB-BOX-PCB Control Box PCB Assembly
31	PWN5452-25X12 Housing Screw
32	PBL1541 Gun Plug Screw

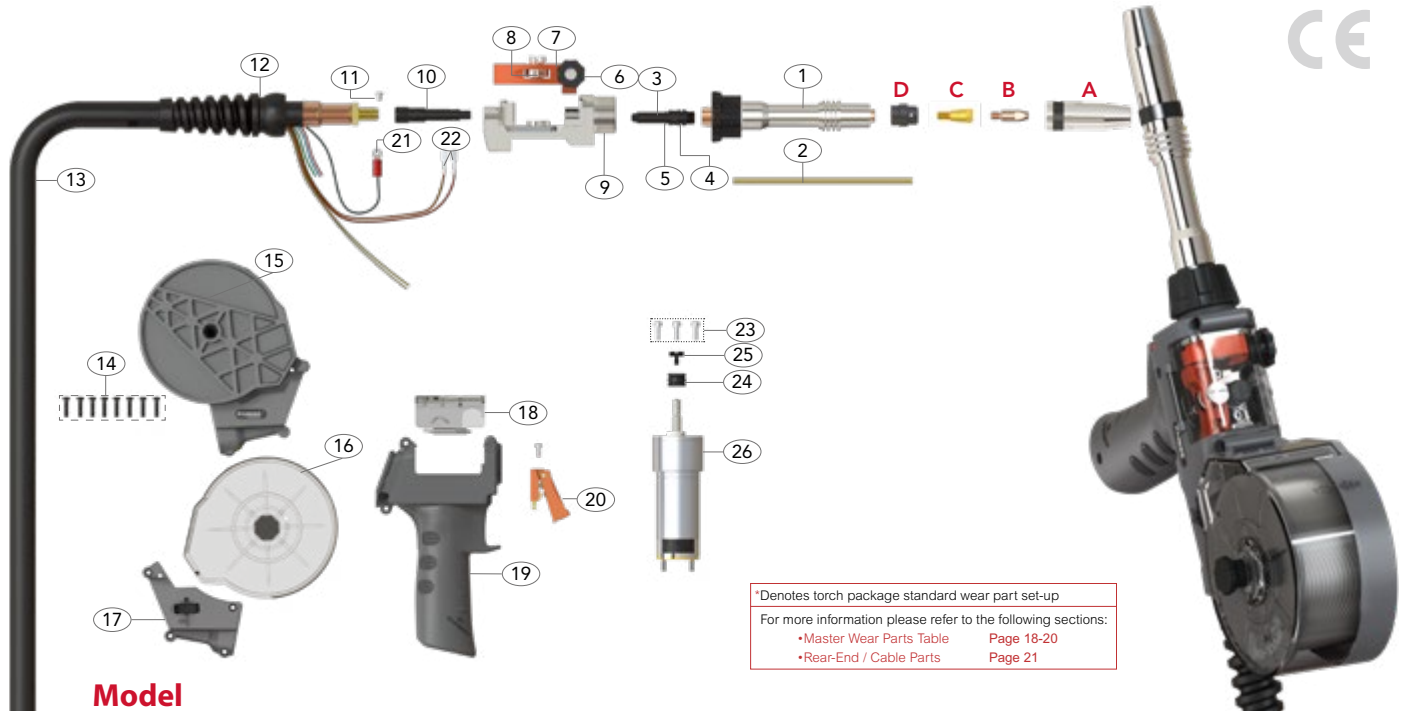

*Denotes torch package standard wear part set-up
For more information please refer to the following sections:
• Master Wear Parts Table Page 18-20
• Rear-End / Cable Parts Page 21

Model

Description	Part No.	
	6mt	8mt
Duragrip AV Spool-On Mig Torch Package Straight Neck, Euro End	DSPAV240A-A180-P10-60ER	DSPAV240A-A180-P10-80ER

Wear Parts

A Nozzles

Part No.	Description	Wall	Material	Bore
PB2415	Cylindrical Nozzle	1.4mm	Cu	17.2
*PB2416	Conical Nozzle	1.4mm	Cu	12.6
PB2417	Tapered Nozzle	1.4mm	Cu	10.0

B Contact Tips

Part No.	Description	Material	Wire Size	
			mm	Inch
PB2504-08	Contact Tip	Cu	0.8	0.030
PB2504-09	Contact Tip	Cu	0.9	0.035
PB2504-10	Contact Tip	Cu	1.0	0.040
PB2504-12	Contact Tip	Cu	1.2	0.045
*PB2504-10A	Contact Tip	Cu	1.0	0.040
PB2504-12A	Contact Tip	Cu	1.2	0.045
PB2505-08	Contact Tip	CuCrZr	0.8	0.030
PB2505-09	Contact Tip	CuCrZr	0.9	0.035
PB2505-10	Contact Tip	CuCrZr	1.0	0.040
PB2505-10A	Contact Tip	CuCrZr	1.0	0.040
PB2505-12A	Contact Tip	CuCrZr	1.2	0.045

C Tip Adaptors

Part No.	Description	Material
*PB2412	Tip Adaptor	Brass

D Diffusers

Part No.	Description	Material	Colour
*PB2405B	Diffuser	DMC3	Black
PB2405C	Diffuser	Ceramic	White
PB2405W	Diffuser	DMC3	White
PB2405S	Diffuser	Silicon	Red

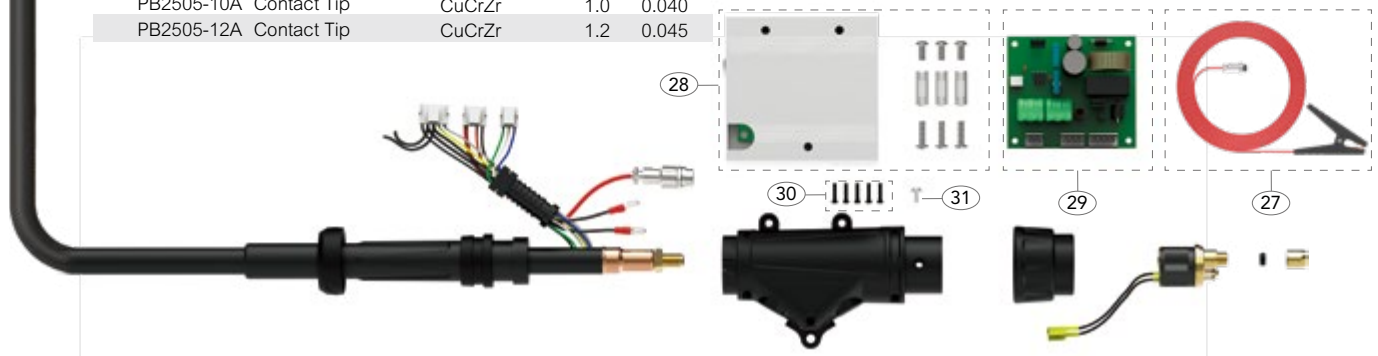

DSPAV 240A Duragrip Spool-On Mig/Mag Torch Range

Rating: 250A CO₂, 220A mixed gas, EN60974-7 @ 35% duty cycle. 0.8 to 1.2mm wires

Air-Cooled Mig Welding Torch



Spare Parts

Part No.	Description
1	PSP2401A Swan Neck Assembly Straight
2	PGP3602A Jump Liner
3	PGP36006 Jump Liner Nipple
4	P9X1.5 'O' Ring
5	P7X1.5 'O' Ring
6	PGP36402B Tension Knob
7	PGP36402 Pressure Arm Assembly
8	PGP36402R Pressure Roll
9	PSP36001 Motor Body
10	PSP36006 Wire Guide Tube
11	SCP2563 Screw
12	PMIG8015 Cable Support
13	DSPCB1517-60ER Coax Cable Assembly Euro Type x 6mt
	DSPCB1517-80ER Coax Cable Assembly Euro Type x 8mt
14	PKA3X20 Handle Screw
15	PSP2515SP-B Wire Spool Holder
16	PSP2515SP-C Wire Spool Cover
17	PSP2515SP-PT-10K Wire Speed Control 10K Ω
18	PGP2514-C Push-Pull Handle Cover

Part No.	Description
19	PCSP2515-KJ Spool-On Handle
20	PGP2516 Standard Trigger Assembly
21	SCP2597 Circular Cable Terminal
22	PB1521 Cable Terminal
23	PGPMS1 Motor Screw
24	SGP7020W-08 Drive Roll For Hard Wire φ 0.8
	SGP7020W-09 Drive Roll For Hard Wire φ 0.9
	SGP7020W-10 Drive Roll For Hard Wire φ 1.0
	SGP7020W-08U Drive Roll For Aluminium Wire φ 0.8
	SGP7020W-09U Drive Roll For Aluminium Wire φ 0.9
	*SGP7020W-10U Drive Roll For Aluminium Wire φ 1.0
	SGP7020W-12U Drive Roll For Aluminium Wire φ 1.2
25	PGP7020-24-4 Drive Roller Retaining Screw
26	SGP7020-24 Motor 24V DC
27	PSP-EL Earth Lead Wire c/w Clamp x 4mt
28	PSPCB-BOX Control Box And Mounting Kit
29	PSPCB-BOX-PCB Control Box PCB Assembly
30	PWN5452-25X12 Housing Screw
31	PBL1541 Gun Plug Screw

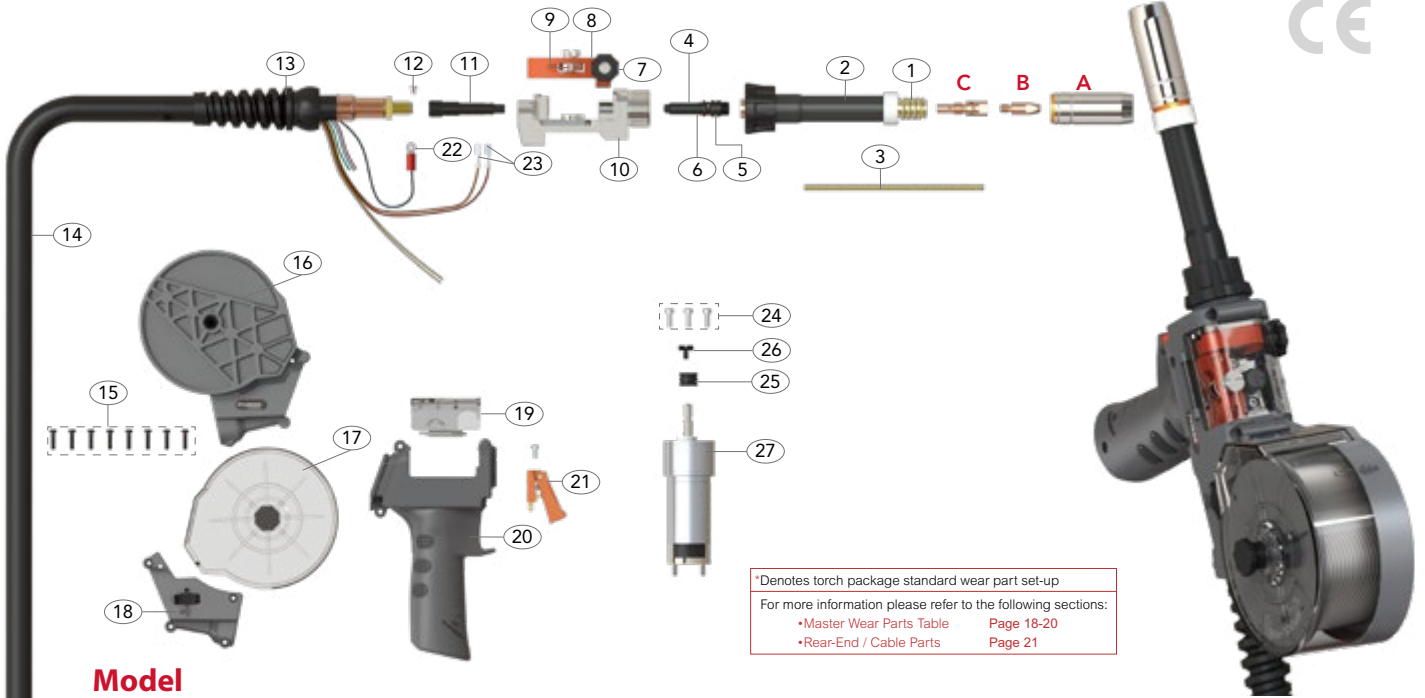

*Denotes torch package standard wear part set-up
For more information please refer to the following sections:
•Master Wear Parts Table Page 18-20
•Rear-End / Cable Parts Page 21

Model

Description	Part No.	
	6mt	8mt
Duragrip AV Spool-On Mig Torch Package Straight Neck, Euro End	DSPAV250A-A180-P10-60ER	DSPAV250A-A180-P10-80ER

Wear Parts

A Nozzles

Part No.	Description	Wall	Material	Bore
PB2507	Cylindrical Nozzle	1.5mm	Cu	18.5
*PB2508	Conical Nozzle	1.5mm	Cu	15.0
PB2509	Tapered Nozzle	1.5mm	Cu	12.0

C Tip Adaptors

Part No.	Description	Material
*PB2506	Tip Adaptor	Brass
PB2536	Tip Adaptor M8	Brass

B Contact Tips

Part No.	Description	Material	Wire Size	
			mm	Inch
PB2504-08	Contact Tip	Cu	0.8	0.030
PB2504-09	Contact Tip	Cu	0.9	0.035
PB2504-10	Contact Tip	Cu	1.0	0.040
PB2504-12	Contact Tip	Cu	1.2	0.045
*PB2504-10A	Contact Tip	Cu	1.0	0.040
PB2504-12A	Contact Tip	Cu	1.2	0.045
PB2505-08	Contact Tip	CuCrZr	0.8	0.030
PB2505-09	Contact Tip	CuCrZr	0.9	0.035
PB2505-10	Contact Tip	CuCrZr	1.0	0.040
PB2505-10A	Contact Tip	CuCrZr	1.0	0.040
PB2505-12A	Contact Tip	CuCrZr	1.2	0.045

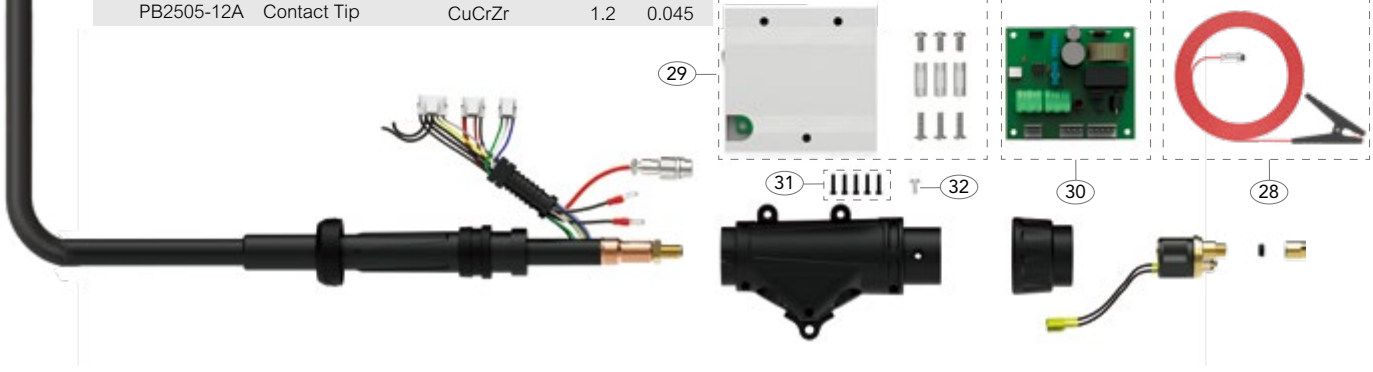

DSPAV 250A Duragrip Spool-On Mig/Mag Torch Range

Rating: 230A CO₂, 200A mixed gas, EN60974-7 @ 35% duty cycle. 0.8 to 1.2mm wires

Air-Cooled Mig Welding Torch



Spare Parts

Part No.	Description
1	PB2502 Shroud Spring
2	PSP2501 Straight Neck Assembly
3	PGP3602A Jump Liner
4	PGP36006 Jump Liner Nipple
5	P9X1.5 'O' Ring
6	P7X1.5 'O' Ring
7	PGP36402B Tension Knob
8	PGP36402 Pressure Arm Assembly
9	PGP36402R Pressure Roll
10	PSP36001 Motor Body
11	PSP36006 Wire Guide Tube
12	SCP2563 Screw
13	PMIG8015 Cable Support
14	DSPCB1517-60ER Coax Cable Assembly Euro Type x 6mt
	DSPCB1517-80ER Coax Cable Assembly Euro Type x 8mt
15	PKA3X20 Handle Screw
16	PSP2515SP-B Wire Spool Holder
17	PSP2515SP-C Wire Spool Cover
18	PSP2515SP-PT-10K Wire Speed Control 10K Ω

Part No.	Description
19	PGP2514-C Push-Pull Handle Cover
20	PCSP2515-KJ Spool-On Handle
21	PGP2516 Standard Trigger Assembly
22	SCP2597 Circular Cable Terminal
23	PB1521 Cable Terminal
24	PGPMS1 Motor Screw
25	SGP7020W-08 Drive Roll For Hard Wire φ 0.8
	SGP7020W-09 Drive Roll For Hard Wire φ 0.9
	SGP7020W-10 Drive Roll For Aluminium Wire φ 1.0
	SGP7020W-08U Drive Roll For Aluminium Wire φ 0.8
	SGP7020W-09U Drive Roll For Aluminium Wire φ 0.9
	*SGP7020W-10U Drive Roll For Aluminium Wire φ 1.0
	SGP7020W-12U Drive Roll For Aluminium Wire φ 1.2
26	PGP7020-24-4 Drive Roller Retaining Screw
27	SGP7020-24 Motor 24V DC
28	PSP-EL Earth Lead Wire c/w Clamp x 4mt
29	PSPCB-BOX Control Box And Mounting Kit
30	PSPCB-BOX-PCB Control Box PCB Assembly
31	PWN5452-25X12 Housing Screw
32	PBL1541 Gun Plug Screw

DSPA360A Duragrip Spool-On Mig/Mag Torch Range

Rating: Long Neck + M8 Tip 300A CO₂, 270A mixed gas, EN60974-7 @ 35% duty cycle. 0.8 to 1.2mm wires
Short Neck + M8 Tip 270A CO₂, 250A mixed gas, EN60974-7 @ 35% duty cycle. 0.8 to 1.2mm wires

Air-Cooled Mig Welding Torch

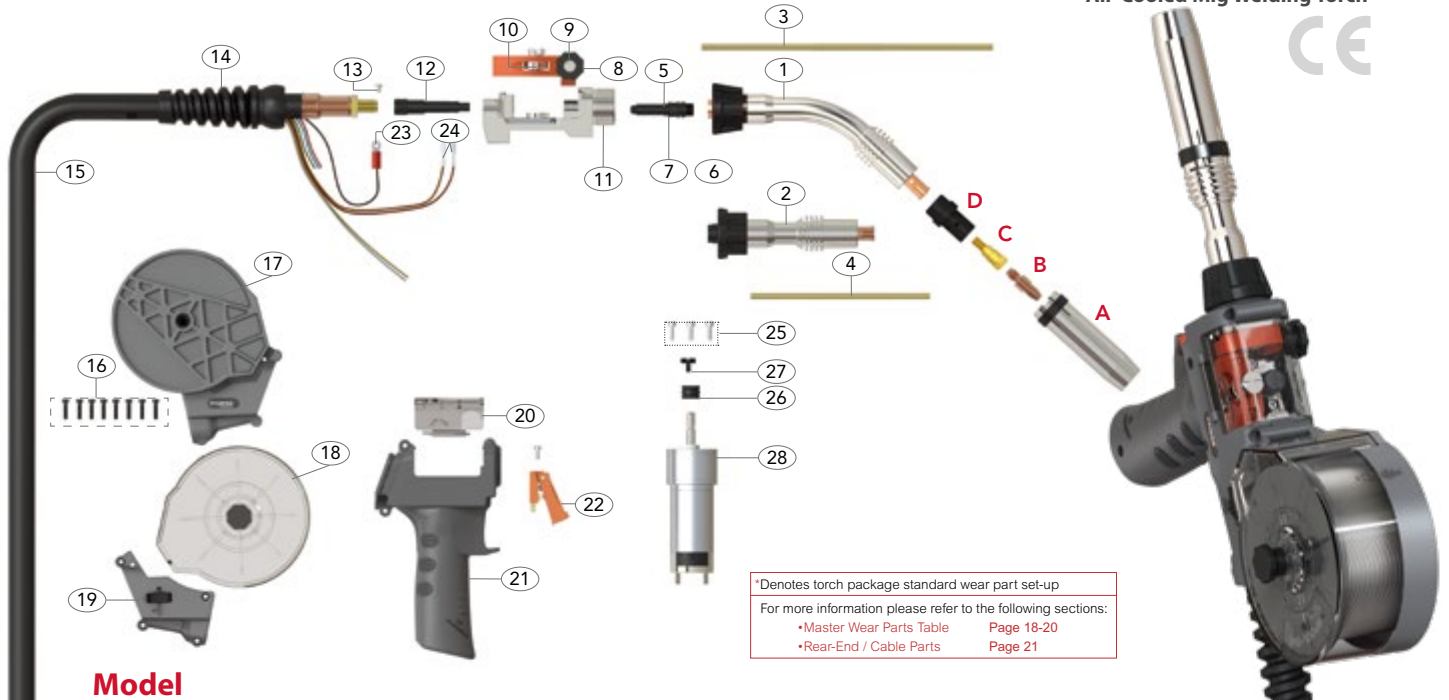

*Denotes torch package standard wear part set-up
For more information please refer to the following sections:
• Master Wear Parts Table Page 18-20
• Rear-End / Cable Parts Page 21

Model

Description	Part No.	
	6mt	8mt
Duragrip AV Spool-On Mig Torch Package 45° Neck, Euro End	DSPA360A-A45-P10-60ER	DSPA360A-A45-P10-80ER
Duragrip AV Spool-On Mig Torch Package Straight Neck, Euro End	DSPA360A-A180-P10-60ER	DSPA360A-A180-P10-80ER

Wear Parts

A Nozzles

Part No.	Description	Wall	Material	Bore
PB3615	Cylindrical Nozzle	2.25mm	Cu	19.0
*PB3616	Conical Nozzle	2.25mm	Cu	16.1
PB3617	Tapered Nozzle	2.25mm	Cu	12.0

B Contact Tips

Part No.	Description	Material	Wire Size	mm	Inch
PB4014-08	Contact Tip	Cu	0.8	0.030	
PB4014-09	Contact Tip	Cu	0.9	0.035	
PB4014-10	Contact Tip	Cu	1.0	0.040	
*PB4014-10A	Contact Tip	Cu	1.0	0.040	
PB4014-12A	Contact Tip	Cu	1.2	0.045	
PB4015-08	Contact Tip	CuCrZr	0.8	0.030	
PB4015-09	Contact Tip	CuCrZr	0.9	0.035	
PB4015-10	Contact Tip	CuCrZr	1.0	0.040	
PB4015-10A	Contact Tip	CuCrZr	1.0	0.040	
PB4015-12A	Contact Tip	CuCrZr	1.2	0.045	

C Tip Adaptors

Part No.	Description	Material
PB3612	Tip Adaptor	Brass
PB3613	Tip Adaptor	Brass
*PB3614	Tip Adaptor	Brass

D Diffusers

Part No.	Description	Material	Colour
*PB3605B	Diffuser	DMC3	Black
PB3605C	Diffuser	Ceramic	White
PB3605W	Diffuser	DMC3	White

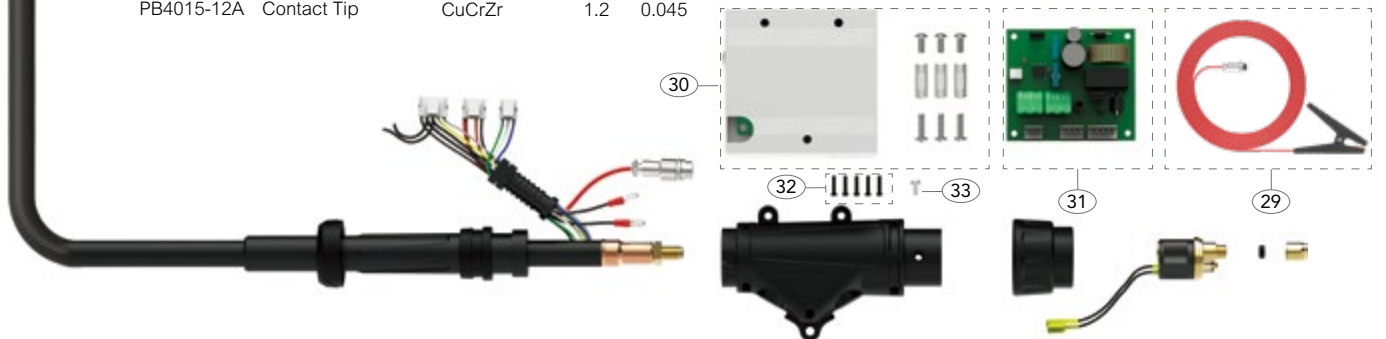

DSPAV 360A Duragrip Spool-On Mig/Mag Torch Range

Rating: Long Neck + M8 Tip 300A CO₂, 270A mixed gas, EN60974-7 @ 35% duty cycle. 0.8 to 1.2mm wires

Short Neck + M8 Tip 270A CO₂, 250A mixed gas, EN60974-7 @ 35% duty cycle. 0.8 to 1.2mm wires

Air-Cooled Mig Welding Torch



Spare Parts

Part No.	Description
1	SGP3603 Swan Neck Assembly 45°
2	SGP3603A Swan Neck Assembly Straight
3	PGP3602 Jump Liner
4	PGP3602A Jump Liner
5	PGP36006 Jump Liner Nipple
6	P9X1.5 'O' Ring
7	P7X1.5 'O' Ring
8	PGP36402B Tension Knob
9	PGP36402 Pressure Arm Assembly
10	PGP36402R Pressure Roll
11	PSP36001 Motor Body
12	PSP36006 Wire Guide Tube
13	SCP2563 Screw
14	PMIG8015 Cable Support
15	DSPCB3617-60ER Coax Cable Assembly Euro Type x 6mt
	DSPCB3617-80ER Coax Cable Assembly Euro Type x 8mt
16	PKA3X20 Handle Screw
17	PSP2515SP-B Wire Spool Holder
18	PSP2515SP-C Wire Spool Cover
19	PSP2515SP-PT-10K Wire Speed Control 10K Ω

Part No.	Description
20	PGP2514-C Push-Pull Handle Cover
21	PCSP2515-KJ Spool-On Handle
22	PGP2516 Straight Trigger Assembly
23	SCP2597 Circular Cable Terminal
24	PB1521 Cable Terminal
25	PGPMS1 Motor Screw
26	SGP7020W-08 Drive Roll For Hard Wire φ 0.8
	SGP7020W-09 Drive Roll For Hard Wire φ 0.9
	SGP7020W-10 Drive Roll For Hard Wire φ 1.0
	SGP7020W-08U Drive Roll For Aluminium Wire φ 0.8
	SGP7020W-09U Drive Roll For Aluminium Wire φ 0.9
	*SGP7020W-10U Drive Roll For Aluminium Wire φ 1.0
	SGP7020W-12U Drive Roll For Aluminium Wire φ 1.2
27	PGP7020-24-4 Drive Roller Retaining Screw
28	SGP7020-24 Motor 24V DC
29	PSP-EL Earth Lead Wire c/w Clamp x 4mt
30	PSPCB-BOX Control Box And Mounting Kit
31	PSPCB-BOX-PCB Control Box PCB Assembly
32	PWN5452-25X12 Housing Screw
33	PBL1541 Gun Plug Screw

DSPA V 150A

Part No.	Description	Bore	Wall	Material
PC1530	Conical Nozzle	12.0	0.95mm	Brass
PB1529	Cylindrical Nozzle	16.0	0.9mm	Cu
*PB1530	Conical Nozzle	12.0	0.9mm	Cu
PB1531	Tapered Nozzle	10.5	0.9mm	Cu
PB1532	Bottle Nozzle	12.8	0.9mm	Cu
PB1533	Spot Welding Nozzle	16.0	0.9mm	Cu

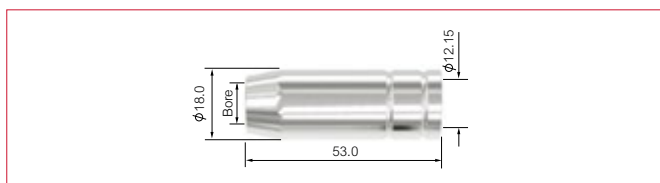

DSPA V 250A

Part No.	Description	Bore	Wall	Material
PC2507	Cylindrical Nozzle	19.0	1.25mm	Brass
PC2508	Conical Nozzle	15.0	1.25mm	Brass
PC2509	Tapered Nozzle	12.0	1.25mm	Brass
PB2507	Cylindrical Nozzle	18.5	1.5mm	Cu
*PB2508	Conical Nozzle	15.0	1.5mm	Cu
PB2509	Tapered Nozzle	12.0	1.5mm	Cu
PB2510	Bottle Nozzle	14.5	1.5mm	Cu
PB2511	Spot Welding Nozzle	18.5	1.5mm	Cu



DSPA V 240A

Part No.	Description	Bore	Wall	Material
PB2415	Cylindrical Nozzle	17.2	1.4mm	Cu
*PB2416	Conical Nozzle	12.6	1.4mm	Cu
PB2417	Tapered Nozzle	10.0	1.4mm	Cu



DSPA V 360A

Part No.	Description	Bore	Wall	Material
PC3615	Cylindrical Nozzle	20.1	1.70mm	Cu
PC3616	Conical Nozzle	16.0	1.70mm	Cu
PC3617	Tapered Nozzle	12.0	1.70mm	Cu
PB3615	Cylindrical Nozzle	19.0	2.25mm	Cu
*PB3616	Conical Nozzle	16.1	2.25mm	Cu
PB3617	Tapered Nozzle	12.0	2.25mm	Cu



* Denotes torch package standard wear part set-up

Contact Tips

DSPAV 150A

Part No.	Description	Material	Wire Size	
			mm	inch
PB1527-06	Contact Tip	Cu	0.6	0.023
*PB1527-08	Contact Tip	Cu	0.8	0.030
PB1527-09	Contact Tip	Cu	0.9	0.035
PB1527-10	Contact Tip	Cu	1.0	0.040
PB1527-08A	Contact Tip	Cu	0.8	0.030
PB1527-09A	Contact Tip	Cu	0.9	0.035
PB1527-10A	Contact Tip	Cu	1.0	0.040

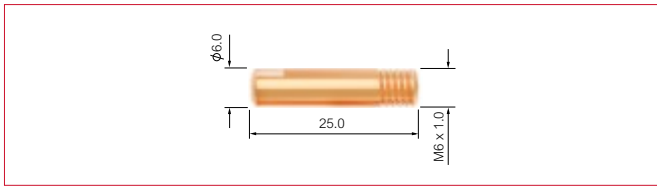

DSPAV 240A/250A

Part No.	Description	Material	Wire Size	
			mm	inch
PB2504-06	Contact Tip	Cu	0.6	0.023
PB2504-08	Contact Tip	Cu	0.8	0.030
PB2504-09	Contact Tip	Cu	0.9	0.035
PB2504-10	Contact Tip	Cu	1.0	0.040
PB2504-12	Contact Tip	Cu	1.2	0.045
*PB2504-10A	Contact Tip	Cu	1.0	0.040
PB2504-12A	Contact Tip	Cu	1.2	0.045

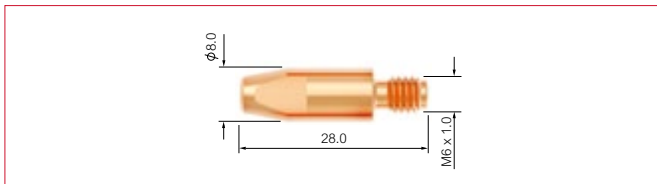

PB2505-08	Contact Tip	CuCrZr	0.8	0.030
PB2505-09	Contact Tip	CuCrZr	0.9	0.035
PB2505-10	Contact Tip	CuCrZr	1.0	0.040
PB2505-10A	Contact Tip	CuCrZr	1.0	0.040
PB2505-12A	Contact Tip	CuCrZr	1.2	0.045

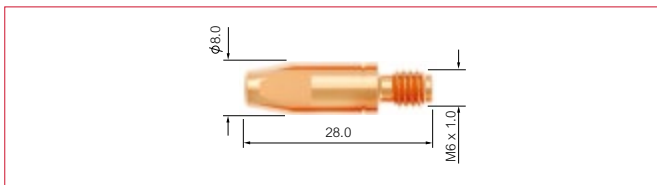

DSPAV 360A

Part No.	Description	Material	Wire Size	
			mm	inch
PB4014-08	Contact Tip	Cu	0.8	0.030
PB4014-09	Contact Tip	Cu	0.9	0.035
PB4014-10	Contact Tip	Cu	1.0	0.040
*PB4014-10A	Contact Tip	Cu	1.0	0.040
PB4014-12A	Contact Tip	Cu	1.2	0.045

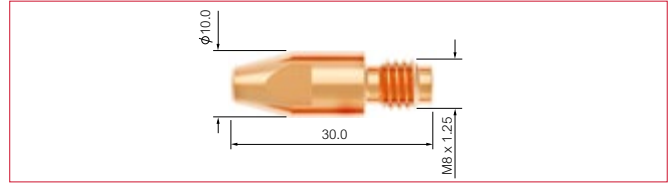

PB4015-08	Contact Tip	CuCrZr	0.8	0.030
PB4015-09	Contact Tip	CuCrZr	0.9	0.035
PB4015-10	Contact Tip	CuCrZr	1.0	0.040
PB4015-10A	Contact Tip	CuCrZr	1.0	0.040
PB4015-12A	Contact Tip	CuCrZr	1.2	0.045

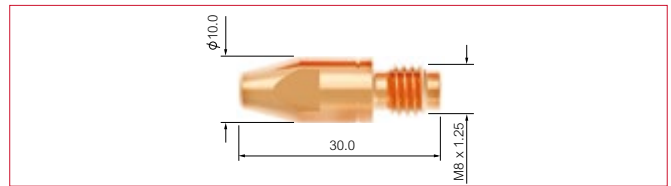

* Denotes torch package standard wear part set-up

Tip Adaptors

DSPAV 150A

Part No.	Description	Material
* PB1507L/H	Tip Adaptor Left Hand	Brass

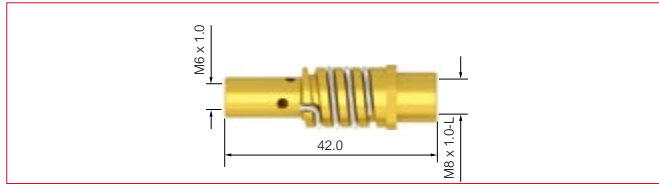

DSPAV 240A

Part No.	Description	Material
* PB2412	Tip Adaptor	Brass

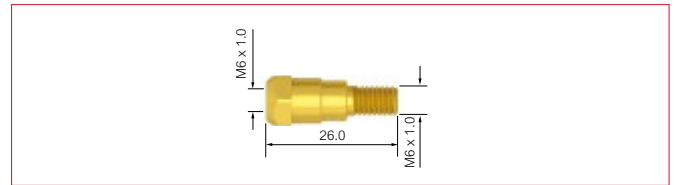

DSPAV 250A

Part No.	Description	Material
* PB2506	Tip Adaptor	Brass

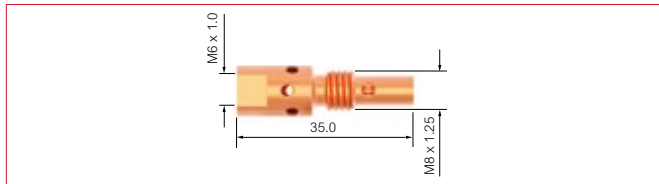

PB2536	Tip Adaptor M8	Brass
--------	----------------	-------

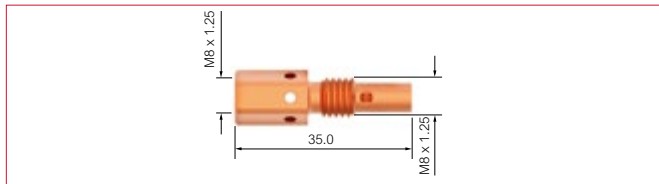

DSPAV 360A

Part No.	Description	Material
PB3612	Tip Adaptor	Brass
PB3613	Tip Adaptor	Brass
* PB3614	Tip Adaptor	Brass

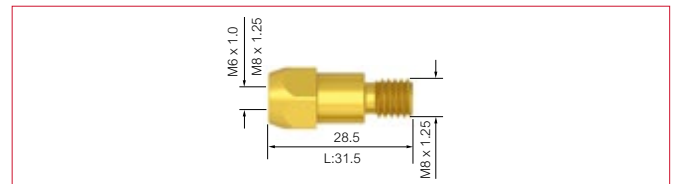

Diffusers

DSPAV 240A

Part No.	Description	Colour	Material
* PB2405B	Diffuser	Black	DMC3
PB2405C	Diffuser	White	Ceramic
PB2405W	Diffuser	White	DMC3
PB2405S	Diffuser	White	Silicon

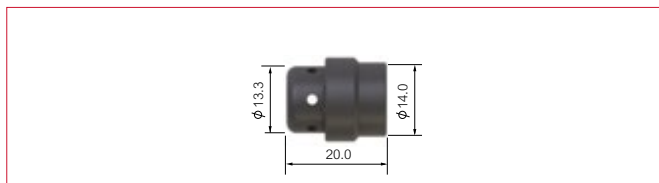

DSPAV 360A

Part No.	Description	Colour	Material
* PB3605B	Diffuser	Black	DMC3
PB3605C	Diffuser	White	Ceramic
PB3605W	Diffuser	White	DMC3

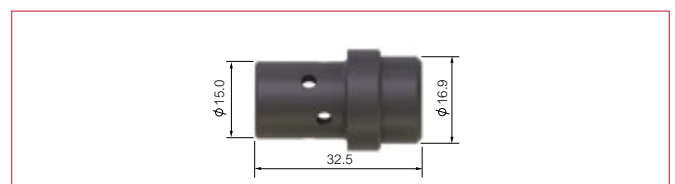

* Denotes torch package standard wear part set-up

Euro Connector

DSPAV 150A/240A/250A

DSPAV 360A

Part No.	Part No.	Description
1 PSC8018	PSC8018	Housing Lock Nut
2 PPA2041	PPA3541	Cable Support
3 PSP-SLH917-L	PSP-SLH917-L	Cable Support Connector
4 PVH3.96-T-5A	PVH3.96-T-5A	5A Connector Female
5 PVH3.96-T-4A	PVH3.96-T-4A	4A Connector Female
6 PVH3.96-T-3A	PVH3.96-T-3A	3A Connector Female
7 PB1505	PB1505	Lock Nut
8 PB1522	PB1522	Cable Terminal Male
9 PSP5022	PSP5022	Housing Assembly c/w Control Box Brackets
10 PB1523	PB1523	Gun Plug Terminal Female
11 PB1519/S	PB1519/S	Euro Housing Nut Assembly
12 PC1528	PC1528	Hybrid Gun Plug Body c/w Spring Pins
13 PB1525W	PB1525W	Gas Seal Gasket
14 PB1525	PB1525	Liner Nut

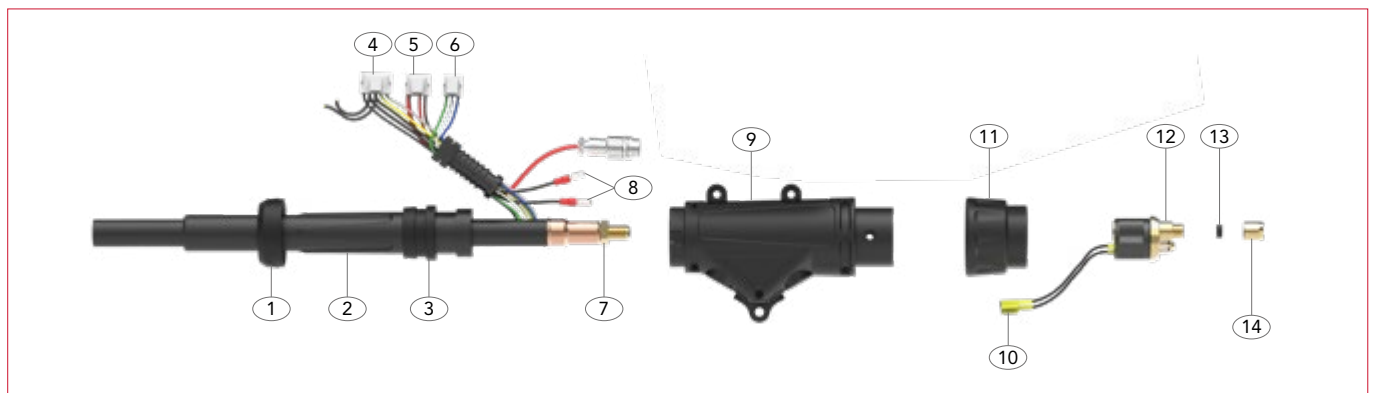



JINAN UNIARC WELDING TECHNOLOGY CO., LTD

13A Zhangjin Comprehensive Bonded Zone
33688, Jing Shi Dong Road
Jinan Area of China (Shandong) Pilot Free Trade Zone
Jinan 250102, P.R. China

Tel: +86 531 88239823

Website: www.parkertorchology.com.cn

Email: info@parkertorchology.com

MPP018 / V.2023.10