

DSP 240A Duragrip Spool-On Mig/Mag Torch Range

Rating: 250A CO₂, 220A mixed gas, EN60974-7 @ 35% duty cycle. 0.8 to 1.2mm wires

Air-Cooled Mig Welding Torch

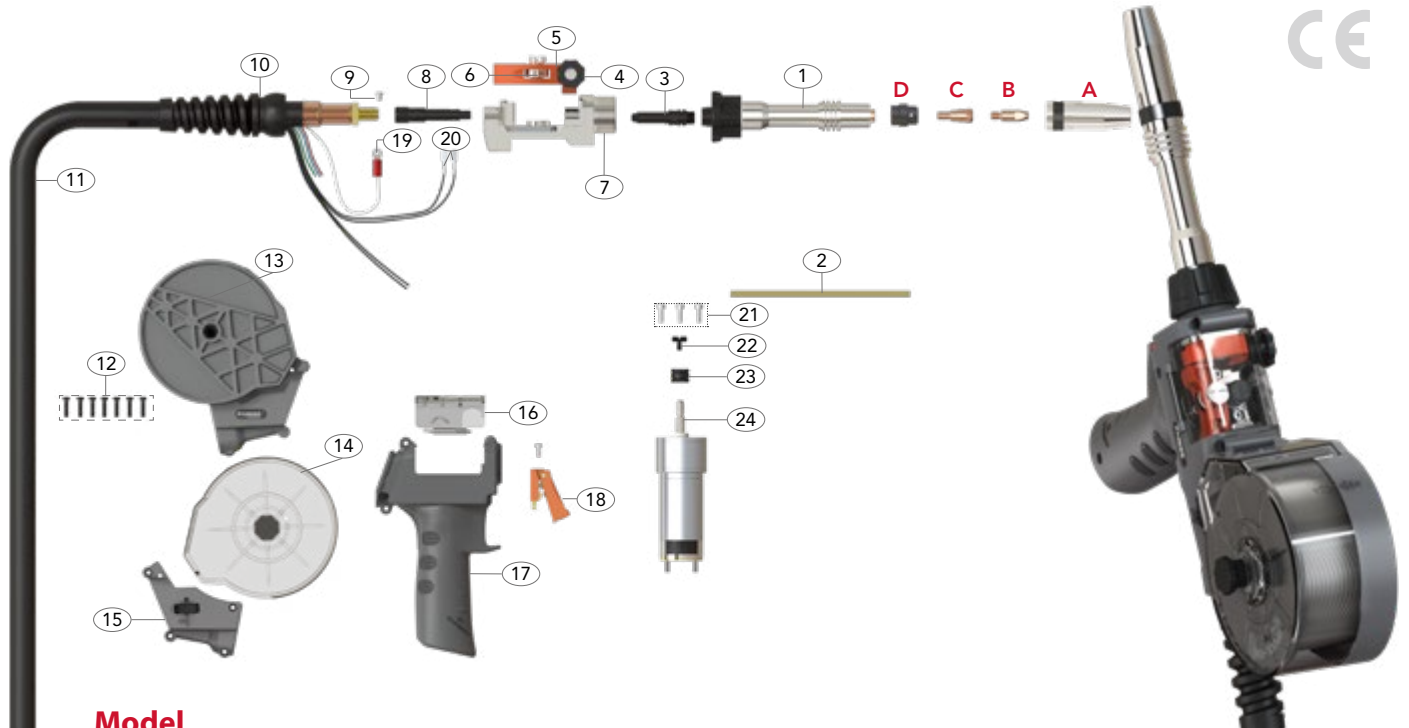

Model

Description	Part No.
	6mt
Spool-On 24V Mig Torch Euro End	DSP240A-24-P1-60ER
Spool-On 42V Mig Torch Euro End	DSP240A-42-P1-60ER
Spool-On 24V Mig Torch Surelok End	DSP240A-24-P1-60DN-GS1
Spool-On 42V Mig Torch Surelok End	DSP240A-42-P1-60DN-GS1

Alternative torch packages can be configured using the configurator on page 9

Wear Parts

A Nozzles

Part No.	Description	Wall	Material	Bore
PB2415	Cylindrical Nozzle	1.40mm	Cu	17.2
*PB2416	Conical Nozzle	1.40mm	Cu	12.6
PB2417	Tapered Nozzle	1.40mm	Cu	10.0

B Contact Tips

Part No.	Description	Material	Wire Size	mm	Inch
PB2504-08	Contact Tip	Cu	0.8	0.030	
PB2504-09	Contact Tip	Cu	0.9	0.035	
PB2504-10	Contact Tip	Cu	1.0	0.040	
PB2504-12	Contact Tip	Cu	1.2	0.045	
*PB2504-10A	Contact Tip	Cu	1.0	0.040	
PB2505-08	Contact Tip	CuCrZr	0.8	0.030	
PB2505-09	Contact Tip	CuCrZr	0.9	0.035	
PB2505-10	Contact Tip	CuCrZr	1.0	0.040	
PB2505-10A	Contact Tip	CuCrZr	1.0	0.040	
PB2505-12A	Contact Tip	CuCrZr	1.2	0.045	

C Tip Adaptors

Part No.	Description	Material
*PB2412	Tip Adaptor	Brass

D Diffusers

Part No.	Description	Material	Colour
*PB2405B	Diffuser	DMC3	Black
PB2405C	Diffuser	Ceramic	White
PB2405W	Diffuser	DMC3	White
PB2405S	Diffuser	Silicon	Red

*Denotes torch package standard wear part set-up
For more information please refer to the following sections:
• Master Wear Parts Table Page 18-20
• Rear-End / Cable Parts Page 21

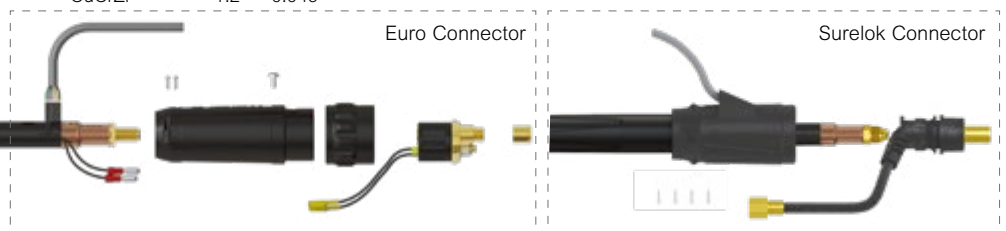

DSP 240A Duragrip Spool-On Mig/Mag Torch Range

Rating: 220A CO₂, 200A mixed gas, EN60974-7 @ 35% duty cycle. 0.8 to 1.2mm wires

Air-Cooled Mig Welding Torch



Spare Parts

Part No.	Description
1	PSP2401A Straight Neck Assembly
2	PGP3602A Jump Liner
3	PGP36006 Jump Liner Nipple
4	PGP36402B Tension Knob
5	PGP36402 Pressure Arm Assembly
6	PGP36402R Pressure Roll
7	PSP36001 Motor Body
8	PSP36006 Wire Guide
9	SCP2563 Screw
10	PMIG8015 Cable Support
11	DSP2403-60ER Coax Cable Assembly, Euro Type
	DSP2403-60DN Coax Cable Assembly, Dinse Type
12	PKA3X20 Handle Screw Pack
13	PSP2515SP-B Spool Holder
14	PSP2515SP-C Spool Cover
15	PSP2515SP-PT-1K Wire Speed Control 1K Ω
	PSP2515SP-PT-5K Wire Speed Control 5K Ω
	PSP2515SP-PT-10K Wire Speed Control 10K Ω
	PSP2515SP-PT-25K Wire Speed Control 25K Ω
	PSP2515SP-PT0 No Potentiometer

Part No.	Description
16	PGP2514-C Push-Pull Handle Cover
17	PCSP2515-KJ Spool-On Handle
18	PGP2516 Push-Pull Trigger
19	SCP2597 Circular Cable Terminal
20	PB1521 Cable Terminal
21	PGPMS1 Motor Screw Pack
22	PGP7020-24-4 Screw
23	SGP7020W-08 Drive Roll For Steel Wire φ 0.8
	SGP7020W-09 Drive Roll For Steel Wire φ 0.9
	SGP7020W-10 Drive Roll For Steel Wire φ 1.0
	SGP7020W-08U Drive Roll For Al Wire φ 0.8
	SGP7020W-09U Drive Roll For Al Wire φ 0.9
	*SGP7020W-10U Drive Roll For Al Wire φ 1.0
	SGP7020W-12U Drive Roll For Al Wire φ 1.2
24	SGP7020-24 Motor 24V DC
	SGP7020-42 Motor 42V DC